

SCREW PUMP REMOVABLE IN 5 MINUTES

PATENT  
**EX**<sup>®</sup>  
GENERATION

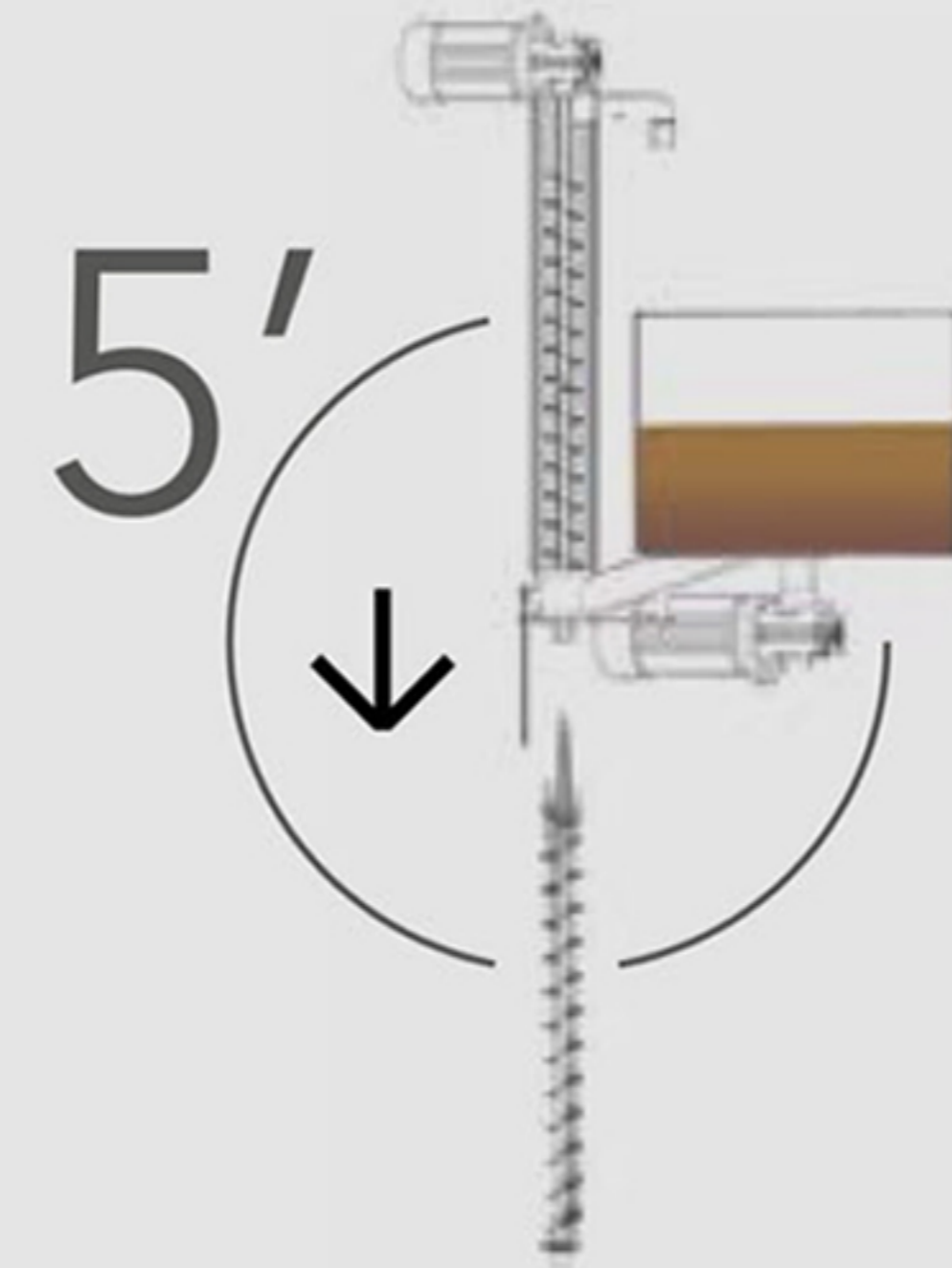

Compact size

Ideal for bakers, ice cream parlours and restaurants

Tempers 12 Kg of chocolate in 8 minutes

New construction concepts resulting in lower energy consumption

Fast melting and tempering of chocolate. Low voltage heated vibrating table. Easy cleaning of the machine thanks to the internal removable screw pump. The advantages of this machine are innumerable, primarily the possibility to insert chopped hazelnuts, cocoa nibs and any product to the chocolate to add aroma. Volumetric dispenser, pedal to control the flow of chocolate. Close circuit cooling system with countercurrent exchanger.

- Option to modify to single phase 220V
- Option to modify to three-phase 220 V - 50/60 Hz
- Possibility of removal of the screw pump to allow for quick washing of the machine interior
- Heated vibrating table 220 V 24 V

PATENT  
**color ex**<sup>®</sup>  
12 KG TANK CAPACITY

CONTINUOUS  
TEMPERING  
MACHINE



#### Technical data

Electrical specification: 400 V three phase 50 Hz  
Power required: 1 kW - 16 A - 5 poles  
Tank capacity: 12 Kg  
Hourly production rate: 55 Kg  
Cooling unit: 900 frigorie/h  
Dimensions: h. 1470 mm, w. 380 mm, d. 740 mm  
inclusive of vibrating table: w. 670 mm